

SolidCAM Electrode Solution

AUTOMATION FOR MOLDBAKERS

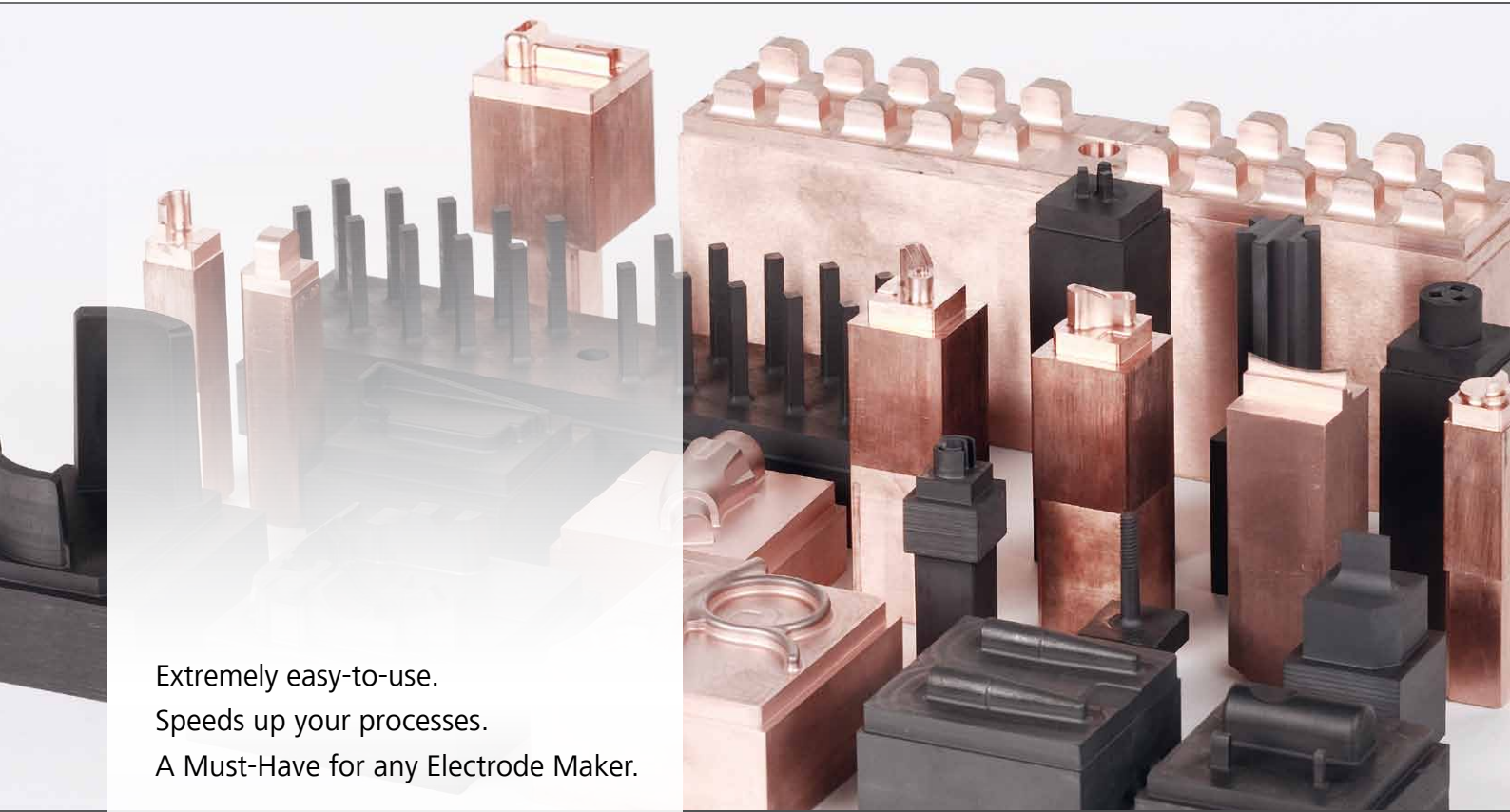

Extremely easy-to-use.
Speeds up your processes.
A Must-Have for any Electrode Maker.

- Automatic electrode design
- Almost no training required
- 100% complete documentation
- Error-free Manufacturing

The SolidCAM Electrode Solution gives you the perfect combination of automation and user control for efficient design and manufacturing of high quality electrodes.



SolidCAM
The Leaders in Integrated CAM

The SolidCAM Electrode Solution

With the increasing complexity and miniaturization of plastic parts, innovative manufacturing technologies like die-sinking EDM become more and more important.

Using the Die-sinking EDM technology, complex molds, dies and metal parts with high quality finish are produced by “burning” electrodes into the metal. This specialized process can be complex and time-consuming and thus influence the lead time of the workpieces.

SolidCAM has developed an Electrode solution that automates time-consuming and repetitive tasks for the electrode design and manufacturing process. It covers the whole process from geometry extraction, documentation, Electrode milling up to the setup for EDM Burning.

GOLD-CERTIFIED SOLIDWORKS INTEGRATION

SolidCAM's electrode solution is fully integrated in SolidWorks. With the single-window integration of SolidCAM in SolidWorks, all electrode design and machining operations are defined, calculated and verified, without leaving the SolidWorks window. All geometries used for machining are fully associative to the SolidWorks electrode design model and the manufacturing module automatically synchronizes all machining operations, if the geometry of the electrode is modified.

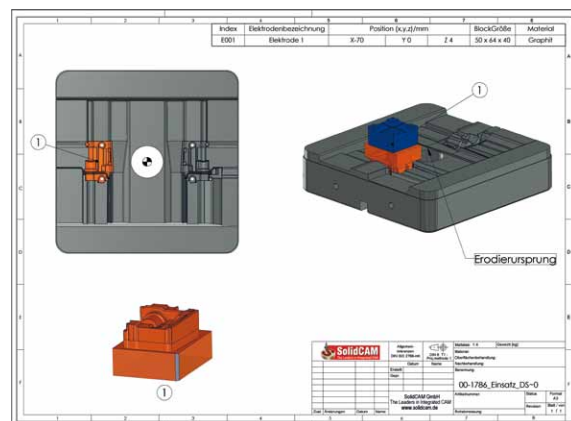
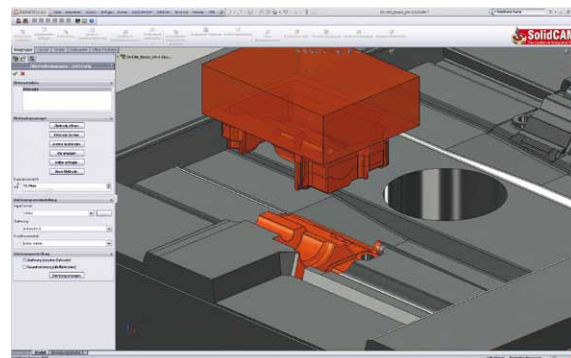

Automated Electrode design with design wizard and automatic generation of manufacturing documentation.

Electrode Design

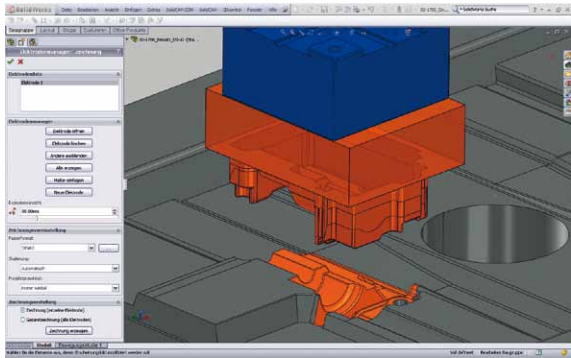

BURN AREA EXTRACTION

After identifying the areas to be manufactured with an electrode, these areas can be enclosed with a 2vD or 3D boundary to define the required electrode geometry. Graphical face selection is also available to permit easy extraction of the more complex areas. SolidCAM's Electrode solution combines automation with the manual ability to construct geometry and apply it to the electrode. This hybrid approach provides the user with the freedom to edit a design and ensures that it will always be possible to complete the electrode design.

ELECTRODE DESIGN

An intuitive Property Manager guides the user through the electrode design process. Options are available to add multiple vertical, angular or tangential extensions, streamlining electrode designs with solid and surface approaches. At any point within the electrode design process, dynamic preview of the surface extensions greatly assists the design.

BLANKS, BASE, STOCK AND HOLDERS

The electrode base and stock are interactively added to the electrode or selected from a standard customizable library. Holders can be designed manually by supplying width, depth and height, or selected from an external library. Where access of the electrode is limited by neighboring surfaces, the holder can be offset from the centre of the electrode to provide enough clearance for the EDM machine. Dynamic animation and collision checking ensure that the entire electrode does not violate the part geometry.

DRAWINGS & DOCUMENTATION

All electrode information are carried through the electrode project to the final report which can be exported to a PDF-file. Shop floor documentation reports and drawings can be created with images and information relevant to burn location and electrode dimensions.

Electrode Manufacturing

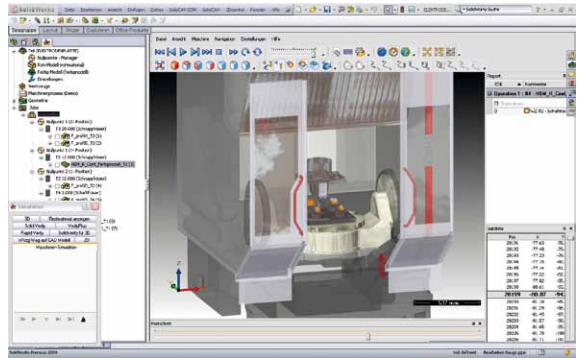

ELECTRODE MACHINING

The SolidCAM Electrode Solution supports a wide range of 2.5D Milling, 3D Milling, High Speed Machining (HSM) and Simultaneous 5-axes strategies, so that any electrode can be optimally manufactured.

SolidCAM's High-Speed machining (HSM) strategies can be used to generate high-quality electrode surfaces. The solution supports negative offsets and thus compensates for the electrode's spark gap.

SolidCAM's simultaneous 5-axis sub-operation for the milling of complex electrodes can be utilized as well. With simultaneous 5-axis machining the user is able to use shorter and more stable tools by rotating the head of the 5-axes machine, rather than working with long tools to machine the electrodes. The use of shorter series cutters improves tool life and surface finish; the tool tilts to avoid collisions with the tool holder, allowing better access to the part geometry.

The SolidCAM Electrode Solution supports templates of complete machining procedures. These templates can be used for the generation of rough, semi-finish and finish electrodes.

TOOL PATH ASSOCIATIVITY

When the electrode geometry is modified in the SolidWorks 3D design, the user can automatically synchronize all machining operations with the updated geometry. The full associativity to the SolidWorks electrode design model reduces errors when the model changes and facilitates the process where updates are received for models already machined.

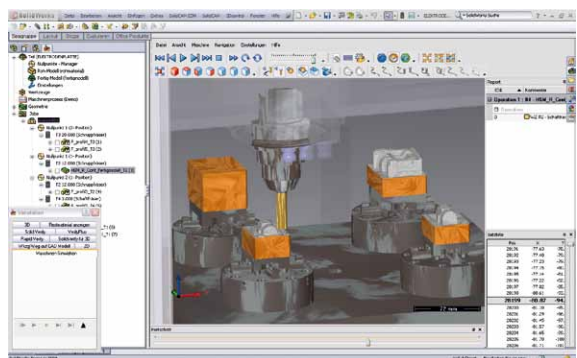

SolidCAM Electrode Solution

AUTOMATION FOR MOLDMAKERS

ELECTRODE DESIGN AUTOMATION

SolidCAM facilitates the design of 3D solid electrodes from flexible surface extensions. The software offers an easy to follow, step-by-step process and addresses all of the common types of electrodes, up to the most complex ones. It supports existing libraries of blanks and holders and generates full documentation for the EDM operator. Even the most experienced electrode designer will benefit from the knowledge-driven automation provided by SolidCAM.

ELECTRODE MANUFACTURING AUTOMATION

Once the electrode design is finished, SolidCAM starts the machining of the electrode in the SolidWorks window. SolidCAM supports a wide range of 2.5D Milling, 3D Milling and High Speed Machining (HSM) strategies for the machining of a very electrode. Machining templates are used to automate the manufacturing of electrodes for both rough and finish stages, using the same geometry.

SolidCAM's Electrode solution provides the right combination of automation and user-control to finish the electrodes with high quality and in time. Moldmakers will benefit from this tool that drastically streamlines the electrode manufacturing process.

